



SPECIFICATIONS

ESDQ
RANGE HOODS

	270 CFM/4.0 Sones (Vertical) @ 0.10" S.P.
	150 CFM/1.5 Sones (Vertical) @ 0.10" S.P., 42.7 Watts
	270 CFM/3.5 Sones (Horizontal) @ 0.10" SP.
	150 CFM/1.1 Sones (Horizontal) @ 0.10" SP., 42.4 Watts

Dimensions

Overall bottom projection - 19 1/2"
Height - 7 1/2"
Widths - 24", 30", 36"

Hood Body

Stainless Steel or 24 gauge cold rolled steel, auto welded, powder coated

Motor

3 speed, thermally protected, permanently lubricated motor. Rated 120 volts, 60 hz. with two electronically balanced blower wheels

Lighting

Electronic Quick Start Ballast – Use GU24 base, 26W CFL lamp.

Ducting Options

Horizontal, Vertical ducting: 3 1/4" x 10" (duct adapter and damper included).
Ductless*: removable front vent (charcoal filter not included)

Mounting

Wall mounted. Install 20" to 30" from cooking surface.

Filters

Grease Filter (included): GF-01 (30", 36" models), GF-07 (24" models).
Charcoal Filter (not included): CF-01 (30", 36" models), CF-07 (24" models).

Available Finishes

Stainless Steel (ESDQ1248, ESDQ1308, ESDQ1368),
White (ESDQ1243, ESDQ1303, ESDQ1363), Biscuit (ESDQ1244, ESDQ1304, ESDQ1364),
Almond (ESDQ1245, ESDQ1305, ESDQ1365), Black (ESDQ1246, ESDQ1306, ESDQ1366)

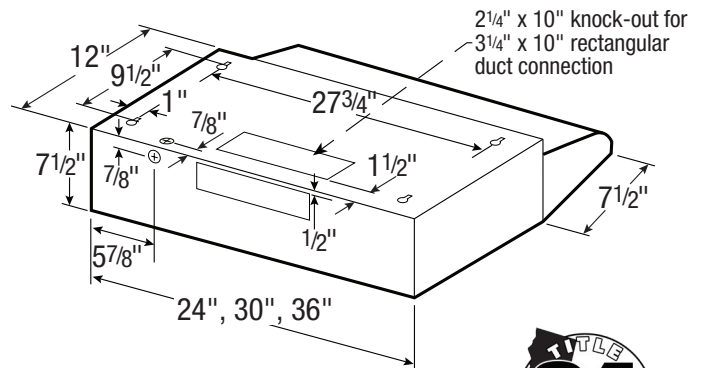
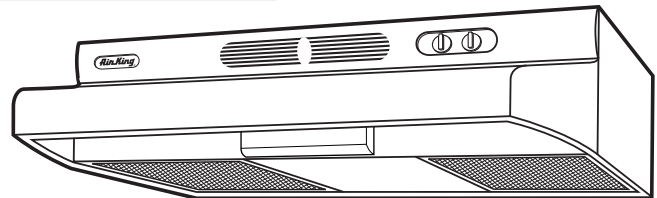

EXPANDED PERFORMANCE

Air Flow - CFM	Static Pressure (inches of w.g.)						Sones @ .1 SP	Fan Speed RPM	Power Watts	Amps
	0	0.1	0.125	0.15	0.2	0.25				
Horz Ducting High Speed	311	270	261	251	225	188	3.5	1653	73.0	1.0
Horz Ducting Med Speed	216	200	195	190	176	142	2.5	1612	58.0	1.0
Horz Ducting Low Speed	163	150	144	137	66	-	1.1	1229	42.4	1.0
Vert Ducting High Speed	310	270	261	251	225	192	4.0	1653	73.0	1.0
Vert Ducting Med Speed	216	200	195	190	176	142	2.5	1612	58.0	1.0
Vert Ducting Low Speed	159	150	148	142	114	44	1.5	1189	42.7	1.0

PROJECT							ARCHITECT				
LOCATION							ENGINEER				
CONTRACTOR							SUBMITTED BY			DATE	
FAN NUMBER	MODEL NUMBER	CFM	IN W.C.	RPM	WATTS	AMPS	SONES	QTY	OPTIONAL EQUIPMENT & REMARKS		



U.S.: 820 Lincoln Avenue
West Chester, Pennsylvania 19380-4466
Tel: (610) 692-7400 • 877-304-3785
Fax: (610) 696-8048

Canada: 8 Edvac Drive
Brampton, Ontario L6S 5P2
Tel: (905) 456-2033 • 800-250-8767
Fax: (905) 456-1015

* The ENERGY STAR Program for Residential Ventilating Fans has no provision for qualification of ductless rangehoods (recirculating not ventilating), as a result the ENERGY STAR program applies to ducted rangehoods only. Specifications subject to change without notice.