



SPECIFICATIONS

**AK90**

EXHAUST FAN



**90 CFM/1.5 Sones @ 0.10" SP.**  
**75 CFM @ 0.25 SP.**

• **Grill**

White, polymeric grill secured in place with torsion springs; easily removed if necessary, dimensions - 11" x 13<sup>3</sup>/<sub>4</sub>".

• **Blower Wheel**

One piece polymeric centrifugal blower wheel, 5<sup>7</sup>/<sub>32</sub>" diameter, 2<sup>29</sup>/<sub>32</sub>" wide, with 30 paddles.

• **Motor**

Heavy duty, permanently split capacitor, plug-in, 4 pole motor, life time lubrication, suitable for continuous operation. Rated 120 volts, 60 hz.

• **Fan Housing**

23 gauge galvanized steel housing.  
 Dimensions: 10<sup>7</sup>/<sub>8</sub>" x 9<sup>3</sup>/<sub>8</sub>" x 7<sup>7</sup>/<sub>8</sub>".

• **Duct Collar**

Plastic collar for 4" duct connection, comes complete with built in non-metallic back draft damper for quiet operation.

• **Ventilating Area**

For bathrooms up to 90 sq. ft. For other rooms up to 115 sq. ft.

• **Electrical Connections**

1/2" electrical knockouts provided.

• **Single Pack Shipping Info**

Box Dim: 14<sup>1</sup>/<sub>8</sub>" x 11<sup>5</sup>/<sub>8</sub>" x 9<sup>5</sup>/<sub>8</sub>"  
 UPC: 0-8316229001-4  
 Shipping Weight: 11.5 lbs.

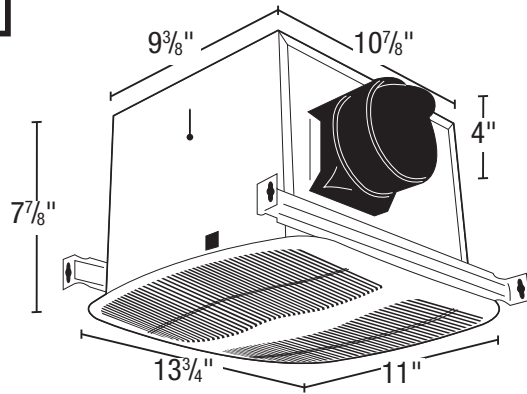

Acceptable for use over tub or shower when installed in a GFCI protected branch circuit.



• **Unit Mounting**

The housing will mount in ceilings with at least 8" of clearance and through drywall thickness up to 3/4", with a rough-in opening of 11<sup>1</sup>/<sub>8</sub>" x 9<sup>5</sup>/<sub>8</sub>". The housing will mount either between 16" or 24" on center joists, using the 4 supplied housing mounting rails. The housing mounting rails can be adapted for overhead mounting (hardware not provided).

**EXPANDED PERFORMANCE**

	Static Pressure (inches of w.g.)							Sones @ .1 SP	Fan Speed RPM	Maximum Fan Watts	Amps
	0	0.05	0.1	0.125	0.15	0.2	0.25				
<b>Air Flow - CFM</b>	97	93	90	89	87	84	75	1.5	1050	25.4	0.3

<b>PROJECT</b>				<b>ARCHITECT</b>					
<b>LOCATION</b>				<b>ENGINEER</b>					
<b>CONTRACTOR</b>				<b>SUBMITTED BY</b>			<b>DATE</b>		
FAN NUMBER	MODEL NUMBER	CFM	IN W.G.	RPM	WATTS	AMPS	SONES	QTY	OPTIONAL EQUIPMENT & REMARKS



**Air King:** 820 Lincoln Avenue  
 West Chester, Pennsylvania 19380-4466  
 Tel: (610) 692-7400 • 877-304-3785  
 Fax: (610) 696-8048