

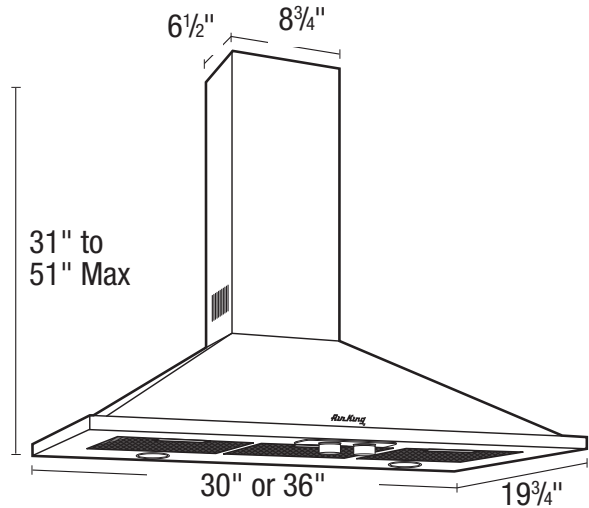

SPECIFICATIONS
ESVAL SERIES
 WALL MOUNT RANGE HOODS

HVI 2100 CERTIFIED High Speed 300 CFM/4.5 Sones @ 0.10" SP.
 Working Speed 170 CFM/1.3 Sones @ 0.03" SP.

- **Dimensions**
 Overall bottom projection - 19³/₄"
 Height (less chimney) - 9¹/₄"
 Available widths - 30" and 36"
- **Hood Body**
 Stainless Steel: 24 gauge, grade 430 stainless steel.
 Painted: 23 gauge cold rolled commercial grade (CRCQ) steel, auto welded, coated with a baked enamel finish.
- **Motor**
 3 speed, permanently split capacitor motor. Rated 120 volts, 60 hz.
- **Lighting**
 Includes 2 - 6.5 Watt GU10 base LED lamps (included).
 4 watt night light (bulb not included).
- **Ducting Options**
 Vertical ducting: 6" round duct adapter complete with polymeric back draft damper ensuring quiet operation.
- **Blower Wheel**
 Dual inlet, electronically balanced polymeric centrifugal blower wheel, 5³/₄" width 59 paddles.
- **Mounting**
 Wall mounted. Install 24" to 36" from cooking surface.
- **Filters**
 Grease Filter: BCGF-01 (included).
 Charcoal Filter: BCCF-02 (not included).
- **Available Finishes**
 Stainless Steel, White, and Black



EXPANDED PERFORMANCE										
Air Flow - CFM	Static Pressure (inches of w.g.)						Sones @ .1 SP	Fan Speed RPM	Fan Watts	Full Load Amps
	0	0.03	0.1	0.25	0.375	0.5				
High Speed	318	313	300	268	231	177	4.5	1282	87.3	1.1
Medium Speed	259	255	245	219	186	130	3.6	987	68.8	
Working Speed	180	175	170	139	107	58	1.3	722	52.3	

PROJECT							ARCHITECT			
LOCATION							ENGINEER			
CONTRACTOR							SUBMITTED BY			DATE
FAN NUMBER	MODEL NUMBER	CFM	IN W.C.	RPM	WATTS	AMPS	SONES	QTY	OPTIONAL EQUIPMENT & REMARKS	



U.S.: 820 Lincoln Avenue
 West Chester, Pennsylvania 19380-4466
 Tel: (610) 692-7400 • 877-304-3785
 Fax: (610) 696-8048

Canada:
 Brampton, Ontario
 Tel: 800-250-8767
 Fax: (905) 456-1015