

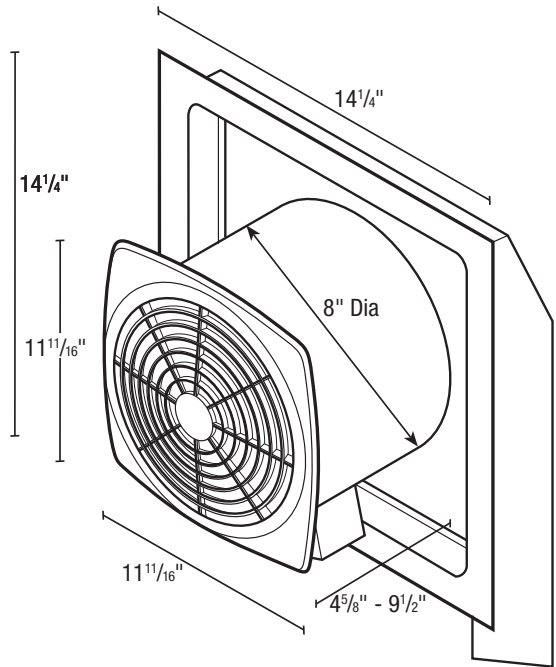

SPECIFICATIONS
EWF-180
EXHAUST FAN

HVI
 CERTIFIED
180 CFM/6.5 Sones @ 0.03" SP.

- **Grill**
 White polymeric grill, dimensions - 11½" x 11½".
- **Blower Wheel**
 Axial Fan Blade – plastic 7.5" Diameter 10 paddle.
- **Motor**
 Heavy duty, permanently split capacitor, plug-in, 4 pole motor, life time lubrication, thermally protected. Rated 120 volts, 60 hz.
- **Fan Housing**
 Rugged heavy gage steel housing finished with electro-statically applied epoxy paint stands up to UV light, water, and temperature extremes.
- **Duct**
 Metal 8" round duct, vents directly to outside, includes springloaded aluminum backdraft damper.
- **Ventilating Area**
 For rooms up to 225 sq. ft.
- **Unit Mounting**
 Exterior wall mounting eliminates the need for ductwork by venting directly outdoors and can be installed in walls 4" to 9" thick.
- **Single Pack Shipping Info**
 Box Dim: 19¼" x 15½" x 10½"
 UPC: 0-8316221801-8
 Shipping Weight: 13.7 lbs.



EXPANDED PERFORMANCE

	Static Pressure (inches of w.g.)							Sones @ .1 SP	Fan Speed RPM	Maximum Fan Watts	Amps
	0	0.03	0.1	0.15	0.2	0.25	0.3				
Air Flow - CFM	193	180	157	147	139	134	131	6.5	2200	80	0.8

PROJECT				ARCHITECT					
LOCATION				ENGINEER					
CONTRACTOR				SUBMITTED BY			DATE		
FAN NUMBER	MODEL NUMBER	CFM	IN W.G.	RPM	WATTS	AMPS	SONES	QTY	OPTIONAL EQUIPMENT & REMARKS



Air King: 820 Lincoln Avenue
 West Chester, Pennsylvania 19380-4466
 Tel: (610) 692-7400 • 877-304-3785
 Fax: (610) 696-8048

Canada:
 Brampton, Ontario
 Tel: 905-456-2033
 Fax: (905) 456-1015

Specifications subject to change without notice.

Updated 2-18