



SPECIFICATIONS
OA SERIES
 DUCTING ADAPTERS

Professional Series Range Hood Ducting Adapters

• **Construction**

Galvanized steel with mounting flange

• **Damper**

Steel ring with aluminum, butterfly type spring loaded damper blades. Included with Vertical Ducting models only. Available separately for other ducting options.

• **Uses**

For use with all Professional and Energy Star® Professional Range Hood Series models

| Adapter Model | Use with Pro Series Blower |
|----------------|----------------------------|
| OA8VD, OA8HD | B300, B500, B600, B900 |
| OA10VD, OA10HD | B1200 |

• **Shipping Information**

Vertical Ducting

OA6VD: UPC: 0-8316230372-1
Shipping Weight: 2.3 lbs.

OA8VD: UPC: 0-8316230382-0
Shipping Weight: 2.3 lbs.

OA10VD: UPC: 0-8316230392-9
Shipping Weight: 2.3 lbs.

Rear Ducting

OA6HD: UPC: 0-8316230343-1
Shipping Weight: 2.3 lbs.

OA8HD: UPC: 0-8316230352-3
Shipping Weight: 2.3 lbs.

OA10HD: UPC: 0-8316230333-2
Shipping Weight: 2.3 lbs.

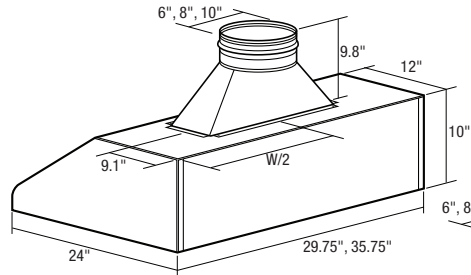

OA8VD Series

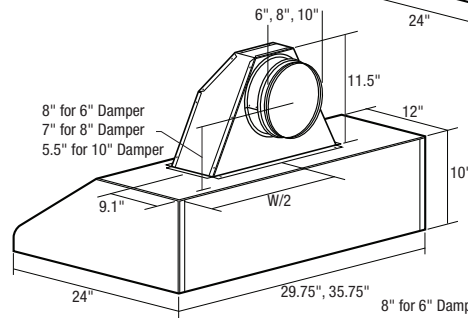
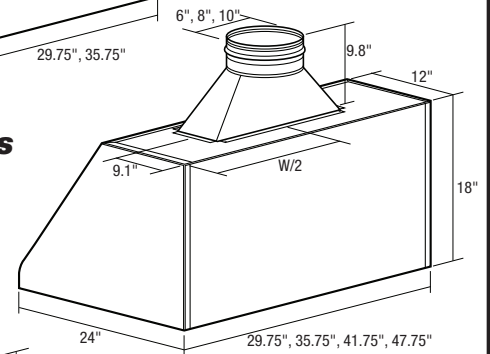

OA6VD Series

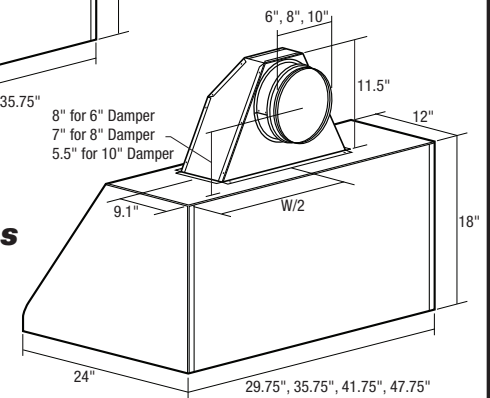

| | | | | | | | | | | |
|-------------------|---------------------|------------|----------------|------------|--------------|-------------|---------------------|------------|---|-------------|
| PROJECT | | | | | | | ARCHITECT | | | |
| LOCATION | | | | | | | ENGINEER | | | |
| CONTRACTOR | | | | | | | SUBMITTED BY | | | DATE |
| FAN NUMBER | MODEL NUMBER | CFM | IN W.C. | RPM | WATTS | AMPS | SONES | QTY | OPTIONAL EQUIPMENT & REMARKS | |
| | | | | | | | | | | |

Air King: 820 Lincoln Avenue
 West Chester, Pennsylvania 19380-4466
 Tel: (610) 692-7400 • 877-304-3785
 Fax: (610) 696-8048