



SPECIFICATIONS
SEV24AB
 POWER PACK

High Speed 300 CFM/4.5 Sones @ 0.10" SP.
Medium Speed 200 CFM/2.5 Sones @ 0.10" SP.
Low Speed 140 CFM/0.7 Sones @ 0.10" SP.

• **Dimensions**

Overall bottom projection - 11"
 Height - 11"
 Width - 19½"

• **Body**

Galvanized steel body with stainless steel fascia. Install at least 24" above the cooking surface.

• **Lighting**

Two - GU10 base, MR16, 50 watt halogen lights.

• **Ducting**

Vertical ducting: 6" round ducting with all metal outlet adapter and back draft damper

• **Filters**

Aluminum grease filters (included).

• **Blower**

3 speed, permanently split capacitor motor. Rated 120 volts, 60 hz. with a dual inlet, electronically balanced polymeric centrifugal blower wheel

• **Cut Out Opening Size**

Width - 18"
 Depth - 10"

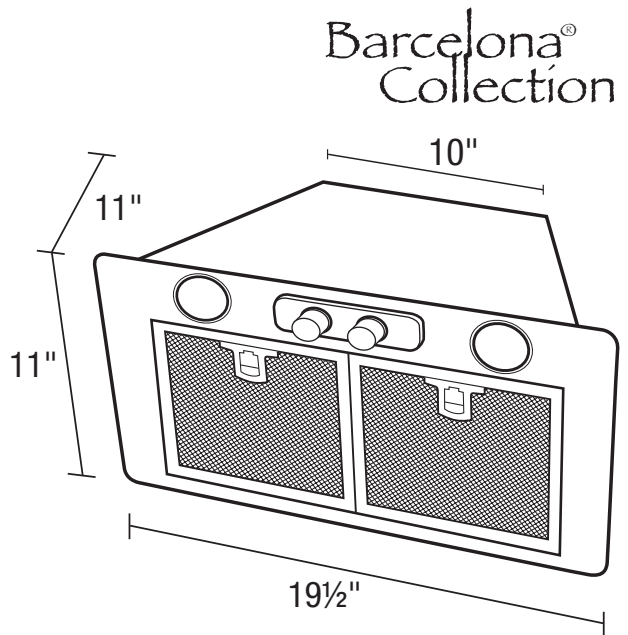

EXPANDED PERFORMANCE

Air Flow - CFM	Static Pressure (inches of w.g.)						Sones @ .1 SP	Fan Speed RPM	Power Watts	Amps
	0	0.1	0.15	0.25	0.3	0.375				
High Speed	315	300	292	271	259	238	4.5	1490	87.3	1.1
Medium Speed	207	200	196	185	178	163	2.5	1335	65.6	1.1
Low Speed	148	140	134	119	109	92	0.7	1080	465.6	1.1

PROJECT							ARCHITECT				
LOCATION							ENGINEER				
CONTRACTOR							SUBMITTED BY			DATE	
FAN NUMBER	MODEL NUMBER	CFM	IN W.C.	RPM	WATTS	AMPS	SONES	QTY	OPTIONAL EQUIPMENT & REMARKS		



Air King: 820 Lincoln Avenue
 West Chester, Pennsylvania 19380-4466
 Tel: (610) 692-7400 • 877-304-3785
 Fax: (610) 696-8048