



SPECIFICATIONS

ECQ

RANGE HOODS



270 CFM/5.0 Sones (Vertical) @ 0.10" S.P.
 160 CFM/1.5 Sones (Vertical) @ 0.03" S.P.
 270 CFM/4.5 Sones (Horizontal) @ 0.10" SP.
 160 CFM/1.5 Sones (Horizontal) @ 0.03" SP.

Continuous Performance @ 0.03" SP.
 30 CFM/<0.3 Sones, 50 CFM/<0.3 Sones
 70 CFM/<0.3 Sones, 90 CFM/<0.3 Sones

Dimensions

Overall bottom projection: 19½"
 Height: 7½" Widths: 24", 30", 36"

Hood Body

Stainless Steel: 24 gauge, grade 430 stainless steel.
 Painted: 23 gauge cold rolled commercial grade (CRCQ) steel, auto welded, coated with a baked enamel finish.

Adjustable Capacity Motor

4 capacity settings on low speed allow the fan to be set to the required exhaust rate for continuous ventilation. Low speed set points include: 30 50 70 or 90 CFM

High speed rapidly clears the air of moisture, odors or other contaminants. Ideal for compliance with Ashrae 62.2, LEED, ENERGY STAR® for Homes, California Title 24 and other programs. Suitable for continuous operation, thermally protected, permanently lubricated, 120V 60 Hz. with two electronically balanced blower wheels.

Internal On/Off switch allows override of continuous ventilation operation.

Lighting

Includes 8.5W LED lamp (included)

Ducting Options

Horizontal, Vertical ducting: 3¼"x 10" (duct collar included).

Mounting

Wall mounted. Install 20" to 30" from cooking surface.

Filters

Grease Filter (included): GF-01 (30", 36" models), GF-07 (24" models).

Available Finishes

Stainless Steel (ECQ308, ECQ368),
 White (ECQ243, ECQ303, ECQ363), Black (ECQ306)

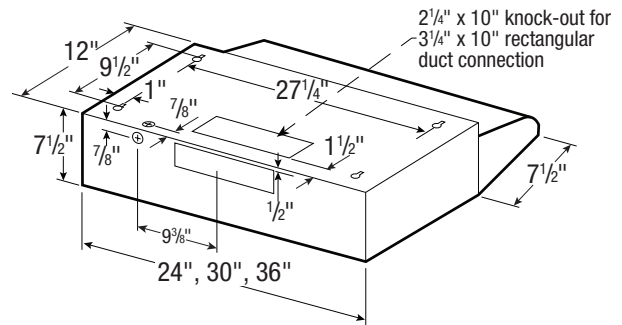
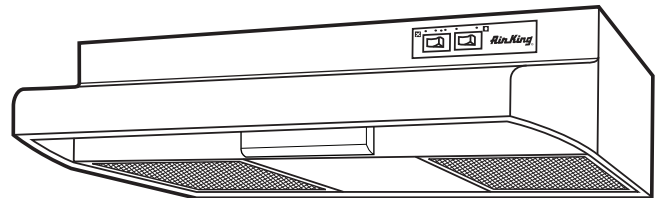

EXPANDED PERFORMANCE

Air Flow - CFM	Static Pressure (inches of w.g.)						Sones @ .1 SP	Fan Speed RPM	Maximum Fan Watts	Amps
	0	0.1	0.125	0.15	0.2	0.25				
High Speed (horizontal)	280	270	241	233	213	175	4.5	1623	72.2	0.8
High Speed (vertical)	281	270	242	232	213	175	5.0	1653	74.0	0.8

Working speed of 160 CFM, 1.5 sones @ 0.03 SP., 44.7 Watts (horizontal), 45.3 Watts (vertical) • 4 steps of adjustment between 30 and 90 CFM for continuous speeds

PROJECT							ARCHITECT				
LOCATION							ENGINEER				
CONTRACTOR							SUBMITTED BY			DATE	
FAN NUMBER	MODEL NUMBER	CFM	IN W.C.	RPM	WATTS	AMPS	SONES	QTY	OPTIONAL EQUIPMENT & REMARKS		



Air King: 820 Lincoln Avenue
 West Chester, Pennsylvania 19380-4466
 Tel: (610) 692-7400 • 877-304-3785
 Fax: (610) 696-8048

Canada:
 Bolton, Ontario
 Tel: 905-456-2033