

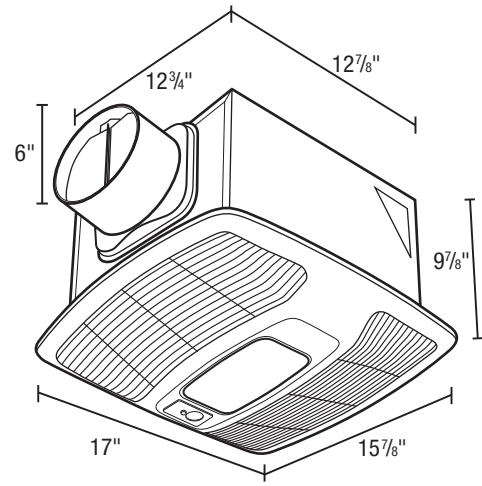

SPECIFICATIONS
EVLDGH
 VARIABLE AIRFLOW DUAL SPEED
 EXHAUST FAN

| | | | |
|--|--|-------------------------------|-------------------------------|
| | 130 CFM/<0.3 Sones @ 0.10" SP. | 90 CFM/<0.3 Sones @ 0.10" SP. | 50 CFM/<0.3 Sones @ 0.10" SP. |
| | 120 CFM/<0.3 Sones @ 0.10" SP. | 80 CFM/<0.3 Sones @ 0.10" SP. | 40 CFM/<0.3 Sones @ 0.10" SP. |
| | 110 CFM/<0.3 Sones @ 0.10" SP. | 70 CFM/<0.3 Sones @ 0.10" SP. | 30 CFM/<0.3 Sones @ 0.10" SP. |
| | 100 CFM/<0.3 Sones @ 0.10" SP. | 60 CFM/<0.3 Sones @ 0.10" SP. | |
| | BOOST SPEED: 150 CFM/0.6 Sones @ 0.10" SP., 112 CFM @ 0.25" SP. | | |

- **Grill**
White, polymeric grill secured in place with torsion springs; easily removed if necessary, dimensions - 17" x 15 7/8".
- **Blower Wheel**
Balanced polymeric dual inlet blower wheel secured in place using a hex nut.
- **Adjustable Capacity Motor**
8 capacity settings on low speed allow the fan to be set to the required exhaust rate for continuous ventilation. Low speed set points include: 30 40 50 60 70 90 100 & 120 CFM
High speed rapidly clears the air of moisture, odors or other contaminants. High speed set points include: 80 110 130 Boost
Quiet 4 Pole motor, suitable for continuous operation, permanently lubricated, 115/120V 60 Hz., 0.30 amps. Ideal for compliance with ASHRAE 62.2, LEED, ENERGY STAR® for Homes, California Title 24 and other programs.
- **Motion Sensor**
Integrated motion sensor automatically turns fan to high speed when room is occupied. Adjustable off delay from 30 seconds to 80 minutes.
- **Humidity Sensor**
Integrated humidity sensor, adjustable up to 80% RH automatically turns fan to high speed until humidity drops to the desired set point.
- **Fan Housing**
23 gauge galvanized steel housing. Overall dimensions: 12 7/8" x 12 3/4" x 9 7/8".
- **Duct Collar**
6" round, zinc plated metal collar adapter. Gasketed, spring loaded aluminum backdraft damper.
- **Electrical Connections**
0.5" electrical knockouts provided. Easy wiring access via either internal or external wiring compartment cover.
- **Lighting**
Dimmable LED Lamp rated 8.5 Watts 800 Lumens 94 Lumens/Watt, 3000K. California Title 24 and JA8 compliant.
- **Single Pack Shipping Info**
Box Dim: 20" x 15 7/8" x 11 1/8"
UPC: 0-8316294098-8
Shipping Weight: 17 lbs.



Acceptable for use over tub or shower when installed in a GFCI protected branch circuit.



- **Unit Mounting**
The housing will mount through drywall thickness up to 3/4", with a rough-in opening of 12 7/8" x 13". The housing will mount either between 16" or 24" on center joists, using the 2 supplied housing mounting brackets. The housing mounting brackets can be adapted for overhead mounting (hardware not provided).

SEE REVERSE SIDE FOR STATIC PRESSURE RANGES

| | | | | | | | | | | |
|-------------------|---------------------|------------|----------------|------------|--------------|-------------|---------------------|------------|---|-------------|
| PROJECT | | | | | | | ARCHITECT | | | |
| LOCATION | | | | | | | ENGINEER | | | |
| CONTRACTOR | | | | | | | SUBMITTED BY | | | DATE |
| FAN NUMBER | MODEL NUMBER | CFM | IN W.G. | RPM | WATTS | AMPS | SONES | QTY | OPTIONAL EQUIPMENT & REMARKS | |
| | | | | | | | | | | |



U.S.: 820 Lincoln Avenue
 West Chester, Pennsylvania 19380-4466
 Tel: (610) 692-7400 • 877-304-3785
 Fax: (610) 696-8048

Canada:
 Bolton, Ontario
 Tel: 905-456-2033



SPECIFICATIONS
EVLDGH
VARIABLE AIRFLOW DUAL SPEED
EXHAUST FAN

ACHIEVABLE STATIC PRESSURES

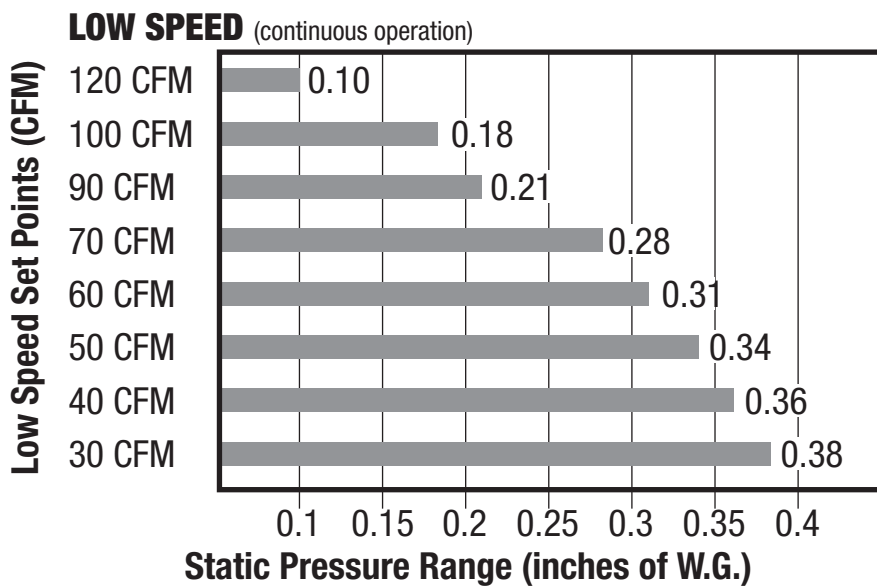
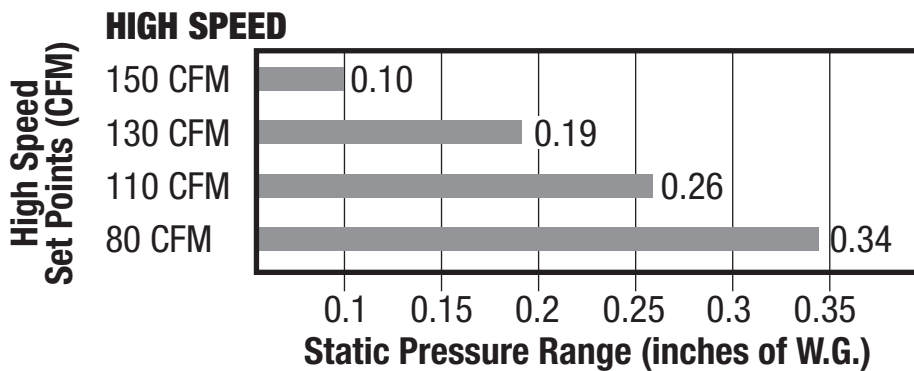

U.S.: 820 Lincoln Avenue
West Chester, Pennsylvania 19380-4466
Tel: (610) 692-7400 • 877-304-3785
Fax: (610) 696-8048

Canada:
Bolton, Ontario
Tel: 905-456-2033