

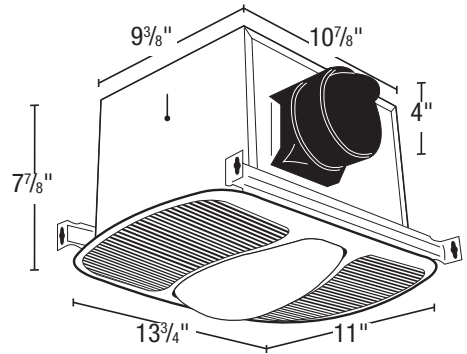

SPECIFICATIONS
LEDAK100D
 EXHAUST FAN WITH LIGHT

100 CFM/2.0 Sones @ 0.10" SP.
83 CFM @ 0.25 SP.
50 CFM/0.4 Sones @ 0.10"

- Grill**
 White, polymeric grill secured in place with torsion springs; easily removed if necessary, dimensions - 11" x 13³/₄". Moonstone glass lens.
- Blower Wheel**
 Balanced polymeric dual inlet blower wheel 5¹/₄" dia. x 2⁷/₈" depth, 30 paddles, secured in place via press fit.
- Motor**
 Enclosed 4 pole electronically balanced permanently split capacitor motor (PSC); life time lubricated, suitable for continuous operation. Motor bearings - ball. Rated 115/120 volts, 60 Hz.
- Fan Housing**
 23 gauge galvanized steel housing.
 Overall dimensions 10⁷/₈" x 9³/₈" x 7⁷/₈".
- Duct Collar**
 Plastic collar for 4" duct connection, comes complete with built in non-metallic back draft damper for quiet operation.
- Ventilating Area**
 For bathrooms up to 100 sq. ft. For other rooms up to 125 sq. ft.
- Electrical Connections**
 1/2" electrical knockouts provided. Easy wiring access via either internal or external wiring compartment cover.
- Lighting**
 Dimmable LED Lamp rated 8.5 Watts 800 Lumens 94 Lumens/Watt, 3000K. **California Title 24 and JAB compliant.**



Acceptable for use over tub or shower when installed in a GFCI protected branch circuit.



- Unit Mounting**
 The housing will mount in ceilings with at least 8" of clearance and through drywall thickness up to 3/4", with a rough-in opening of 11¹/₈" x 9⁹/₈". Rated for ceilings insulated to R-40. The housing will mount either between 16" or 24" on center joists, using the 4 supplied housing mounting rails. The housing mounting rails can be adapted for overhead mounting (hardware not provided).
- Single Pack Shipping Info**
 Box Dim: 15¹⁵/₁₆" x 14⁵/₁₆" x 9⁷/₈"
 UPC: 0-8316294074-2
 Shipping Weight: 13.6 lbs.

EXPANDED PERFORMANCE											
Air Flow - CFM	Static Pressure (inches of w.g.)							Sones @ .1 SP	Fan Speed RPM	Maximum Fan Watts	Amps
	0	0.05	0.1	0.15	0.2	0.25	0.35				
High Speed	108	104	100	95	90	83	43	2.0	1182	26.5	0.6
Low Speed	55	53	50	46	41	30	-	0.4			

PROJECT							ARCHITECT				
LOCATION							ENGINEER				
CONTRACTOR							SUBMITTED BY			DATE	
FAN NUMBER	MODEL NUMBER	CFM	IN W.G.	RPM	WATTS	AMPS	SONES	QTY	OPTIONAL EQUIPMENT & REMARKS		



U.S.: 820 Lincoln Avenue
 West Chester, Pennsylvania 19380-4466
 Tel: (610) 692-7400 • 877-304-3785
 Fax: (610) 696-8048

Canada:
 Brampton, Ontario
 Tel: 905-456-2033
 Fax: (905) 456-1015