

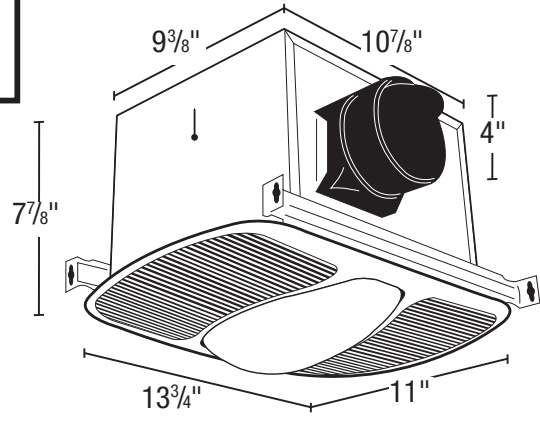

SPECIFICATIONS
LEDAK100
 EXHAUST FAN WITH LIGHT

2100 HVI CERTIFIED **100 CFM/2.0 Sones @ 0.10" SP.**
83 CFM @ 0.25" SP.



- **Grill**
 White, polymeric grill secured in place with torsion springs; easily removed if necessary, dimensions - 11" x 13 3/4". Moonstone glass lens.
- **Blower Wheel**
 Balanced polymeric dual inlet blower wheel 5 1/4" dia. x 2 7/8" depth, 30 paddles, secured in place via press fit.
- **Motor**
 Enclosed 4 pole electronically balanced permanently split capacitor motor (PSC); life time lubricated, suitable for continuous operation. Motor bearings - ball. Rated 115/120 volts, 60 Hz.
- **Fan Housing**
 23 gauge galvanized steel housing. Overall dimensions 10 7/8" x 9 9/8" x 7 7/8".
- **Duct Collar**
 Plastic collar for 4" duct connection, comes complete with built in non-metallic back draft damper for quiet operation.
- **Ventilating Area**
 For bathrooms up to 100 sq. ft. For other rooms up to 125 sq. ft.
- **Electrical Connections**
 1/2" electrical knockouts provided. Easy wiring access via either internal or external wiring compartment cover.
- **Lighting**
 Dimmable LED Lamp rated 8.5 Watts 800 Lumens 94 Lumens/Watt, 3000K. **California Title 24 and JA8 compliant.**

Acceptable for use over tub or shower when installed in a GFCI protected branch circuit.



- **Unit Mounting**
 The housing will mount in ceilings with at least 8" of clearance and through drywall thickness up to 3/4", with a rough-in opening of 11" x 9 1/2". Rated for ceilings insulated to R-40. The housing will mount either between 16" or 24" on center joists, using the 4 supplied housing mounting rails. The housing mounting rails can be adapted for overhead mounting (hardware not provided).
- **Single Pack Shipping Info**
 Box Dim: 16" x 14 3/8" x 9 7/8"
 UPC: 0-8316294081-0
 Shipping Weight: 13.6 lbs.

EXPANDED PERFORMANCE

	Static Pressure (inches of w.g.)							Sones @ .1 SP	Fan Speed RPM	Maximum Fan Watts	Amps
	0	0.5	0.1	0.15	0.2	0.25	0.375				
Air Flow - CFM	108	104	100	95	90	83	70	2.0	1182	26.5	0.60

PROJECT					ARCHITECT						
LOCATION					ENGINEER						
CONTRACTOR					SUBMITTED BY					DATE	
FAN NUMBER	MODEL NUMBER	CFM	IN W.G.	RPM	WATTS	AMPS	SONES	QTY	OPTIONAL EQUIPMENT & REMARKS		



U.S.: 820 Lincoln Avenue
 West Chester, Pennsylvania 19380-4466
 Tel: (610) 692-7400 • 877-304-3785
 Fax: (610) 696-8048

Canada:
 Bolton, Ontario
 Tel: 905-456-2033