

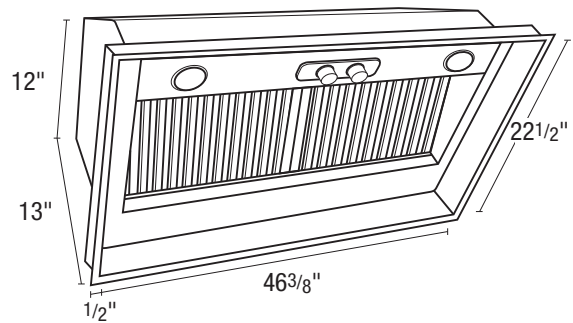

SPECIFICATIONS  
**LIN46MD**  
 POWER UNIT LINER

LIN46md-600 CFM/5.5 Sones @ 0.10" SP.  
 LIN46md-900 CFM/11.0 Sones @ 0.10" SP.  
 LIN46md-1200 CFM/15.0 Sones @ 0.10" SP.

- Hood**  
 Galvanized metal body with all exposed areas grade 430 stainless steel. Approved for installation into covered outdoor kitchen areas.
- Thermostat**  
 Thermostat detects when the heat level rises to an excessive amount and automatically turns the hood on.
- Blower Wheel**  
 Dual inlet, electronically balanced centrifugal blower wheels, 57/8" width 59 paddles.
- Lighting**  
 2 - ENERGY STAR® certified PAR20, E26 screw-in base, 7 watt, 500 lumens LED lamps (included).
- Ducting Options**  
 Vertical outlet only. Vertical or Horizontal ducting transition achieved through vertical (included) or horizontal (optional) outlet adapter specified for size of motor.
- Filters**  
 Grease Baffles: Dishwasher safe, Stainless Steel baffles (included).
- Available Finishes**  
 Brushed Stainless Steel - #4 finish
- Opening Size**  
 46<sup>3</sup>/<sub>8</sub>" x 22<sup>1</sup>/<sub>2</sub>" (Fits cabinets 48" wide)



NOTE: 1/2" wide trim flange around the entire perimeter of the face plate

EXPANDED PERFORMANCE										
Air Flow - CFM	Static Pressure (inches of w.g.)						Sones @ .1 SP	Fan Speed RPM	Blower Watts	Full Load Amps
	0	0.1	0.25	0.375	0.5	0.625				
600 CFM Blower	638	600	537	458	342	143	5.5	1492	164	1.25
900 CFM Blower	918	900	874	852	829	805	11.0	2051	604	5.70
1200 CFM Blower	1222	1200	1168	1142	1117	1090	15.0	2617	945	7.20

PROJECT							ARCHITECT			
LOCATION							ENGINEER			
CONTRACTOR							SUBMITTED BY			DATE
FAN NUMBER	MODEL NUMBER	CFM	IN W.C.	RPM	WATTS	AMPS	SONES	QTY	OPTIONAL EQUIPMENT & REMARKS	



**Air King:** 820 Lincoln Avenue  
 West Chester, Pennsylvania 19380-4466  
 Tel: (610) 692-7400 • 877-304-3785  
 Fax: (610) 696-8048

**Canada:**  
 Bolton, Ontario  
 Tel: 905-456-2033