

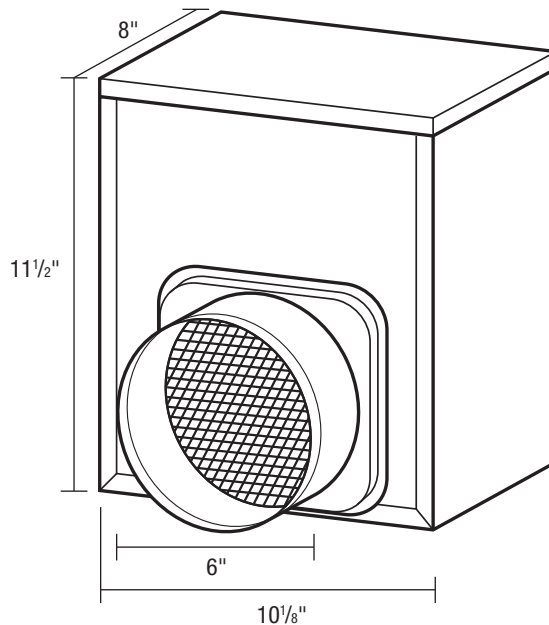

SPECIFICATIONS
QH900
 HEATER

HEATING ELEMENT ACCESSORY
 (use for setting of 70 CFM and higher)

- **Blower Wheel**
One piece polymeric, 2⁵/₈" x 4¹/₂" with 48 fins.
- **Motor**
2 pole motor, lifetime lubrication, thermally protected. Rated 120 volts, 60hz.
- **Housing**
26 gauge baked epoxy housing. Internally lined with closed cell thermal insulation. Dimensions: 11¹/₂"H x 8"D x 10¹/₈"W (total of 22⁷/₈" W including QFAM unit).
- **Heating Element**
Ceramic heating element bonded to large heat transfer surface allows heating at very low operating temperature. 2 stage self regulating design provides 900 Watts or 450 Watts.
- **Duct Collars**
6" round, zinc plated metal collar with integrated protection screen (taken from QFAM unit).
- **Electrical Connections**
Connects to existing wiring of QFAM unit via a quick connect molex connection.
- **Electrical Ratings**
120V, 60Hz, 9.0 amps (includes QFAM).
- **Unit Mounting**
Mounts to QFAM model fresh air supply fans ONLY.



<i>Adjusted Air Flow @ 0.2 inches of static pressure (in. w.g.)</i>										
Unit Dial Setting	40	50	60	70	80	90	100	110	120	130
CFM with Heating Element	30	40	48	56	65	75	84	92	100	108

PROJECT					ARCHITECT				
LOCATION					ENGINEER				
CONTRACTOR					SUBMITTED BY			DATE	
FAN NUMBER	MODEL NUMBER	CFM	IN W.G.	RPM	WATTS	AMPS	SONES	QTY	OPTIONAL EQUIPMENT & REMARKS



820 Lincoln Avenue • West Chester, Pennsylvania 19380-4466